

Water tank truck



LH12-30

Optional specifications are contained in the photograph.

Standard equipments



▲ Level gauge



▲ Pump



▲ Manhole



▲ 4-way cock



▲ 2-way cock

The vehicle in the photographs include optional equipments, special coloring and processing.

Simple mechanism with high durability



LH10-30

Optional specifications are contained in the photograph.

Specifications

Model	LH02-30	LH04-30	LH08-30	LH10-30	LH13-30	LH15-30	LH20-30
Tank capacity (Liter)	2,000	4,000	8,000	10,000	13,000	15,000	20,000
Pump type	Centrifugal						
Pump performance	Flow capacity	500L/min			550L/min		
	Pressure	295kPa(3.0kgf/cm)			490kPa(5.0kgf/cm)		
	Total head	30m			50m		
Piping diameter	50mm			63mm			
Hose	Diameter 50mm × 2,000~6,000mm × 2pcs			Diameter 63mm × 3,000mm × 2pcs			
Manhole	Diameter 400mm			Diameter 400mm			
Plate thickness	Shell plate	3.2mm			3.2mm · 4.5mm		
	End plate	3.2mm			3.2mm		
	Baffle plate	3.2mm			3.2mm		
GVW (kg)	5,000~6,000	7,500~9,000	13,000~17,000	16,000~22,000	21,000~25,000	25,000~27,000	33,000~35,000

The above mentioned figures are approximate.

Structure

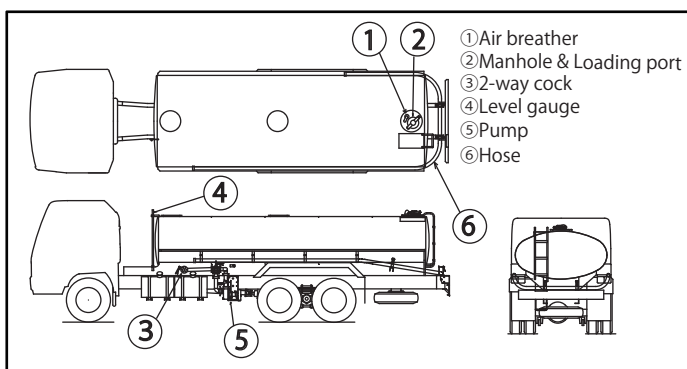

Optional specifications are contained in the Structure.

Piping diagram

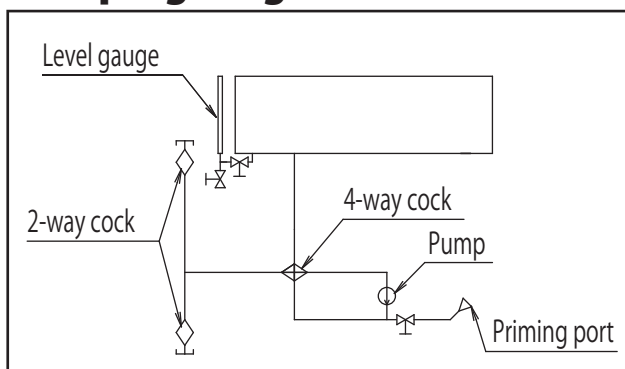

Note : Specifications and the other contents on this catalogue are subject to change without prior notice due to product improvement.
Product photos on this catalogue might include optional devices.

Kyokuto Kaihatsu Kogyo Co., Ltd.

TOKYO OFFICE

1-1, Haneda Asahicho, Ohta-ku, Tokyo, 144-0042, Japan
Telephone : +81 (3) 5737-2281 Facsimile : +81 (3) 5737-2282
E-mail : web-overseas@kyokuto.com
http://www.kyokuto.com/