

Sprinkler truck



LH13-30

Optional specifications are contained in the photograph.

■ Standard equipments



▲ Level gauge



▲ Pump



▲ Manhole



▲ 4-way cock



▲ Spray bar

The vehicle in the photographs include optional equipments, special coloring and processing.

Simple mechanism with high durability

■ Optional equipments

● Rear sprinkler



■ Specifications

Model	LH02-30	LH04-30	LH08-30	LH10-30	LH13-30	LH15-30	LH20-30
Tank capacity (Liter)	2,000	4,000	8,000	10,000	13,000	15,000	20,000
Pump type	Centrifugal						
Pump performance	Flow capacity	500L/min			550L/min		
	Pressure	295kPa(3.0kgf/cm ²)			490kPa(5.0kgf/cm ²)		
	Total head	30m			50m		
Piping diameter	50mm			63mm			
Hose	Diameter 50mm × 2,000mm × 2pcs			Diameter 63mm × 3,000mm × 2pcs			
Manhole				Diameter 400mm			
Plate thickness	Shell plate	3.2mm			3.2mm · 4.5mm		
	End plate				3.2mm		
	Baffle plate				3.2mm		
GVW (kg)	5,000~6,000	7,500~9,000	13,000~17,000	16,000~22,000	21,000~25,000	25,000~27,000	33,000~35,000

The above mentioned figures are approximate.

■ Structure

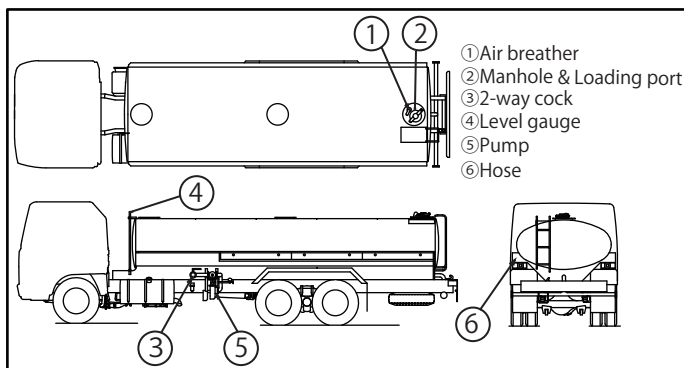

■ Piping diagram

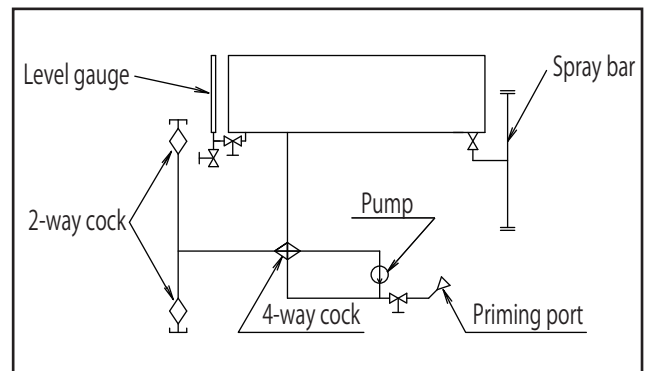

Note : Specifications and the other contents on this catalogue are subject to change without prior notice due to product improvement.

Product photos on this catalogue might include optional devices.

Kyokuto Kaihatsu Kogyo Co., Ltd.

TOKYO OFFICE

3-15-10, Higashi-shinagawa, Shinagawa-ku, Tokyo, 140-0002, Japan

Telephone : +81(3)5781-9828 Facsimile : +81(3)5781-3438

E-mail : web-overseas@kyokuto.com

http://www.kyokuto.com/